

LOC	DIST	REVISIONS					
		P.	LTR	DESCRIPTION	DATE	DWN	APVD
HM	00	A		NSD07-041	30MAY2007	JM	SH
		B		REV: ECO-07-022804	10OCT2007	GG	SH

- △ MATERIAL:
 CONNECTOR HOUSING, INTERFACE: POLYESTER MOLDING COMPOUND, BLACK.
 PANEL: BLACK POWDER COAT STEEL WITH WHITE MARKINGS.
 AMPTRAC CONTACT : PHOS BRONZE.
2. FOUR BLACK 12-24 X 12.7 [.500] LONG AND FOUR 10-32 X 12.7 [.500] LONG CARBON STEEL CROSS RECESSED SCREWS FOR MOUNTING OF PANEL, SHIPPED LOOSE. NOT SHOWN ON DRAWING.

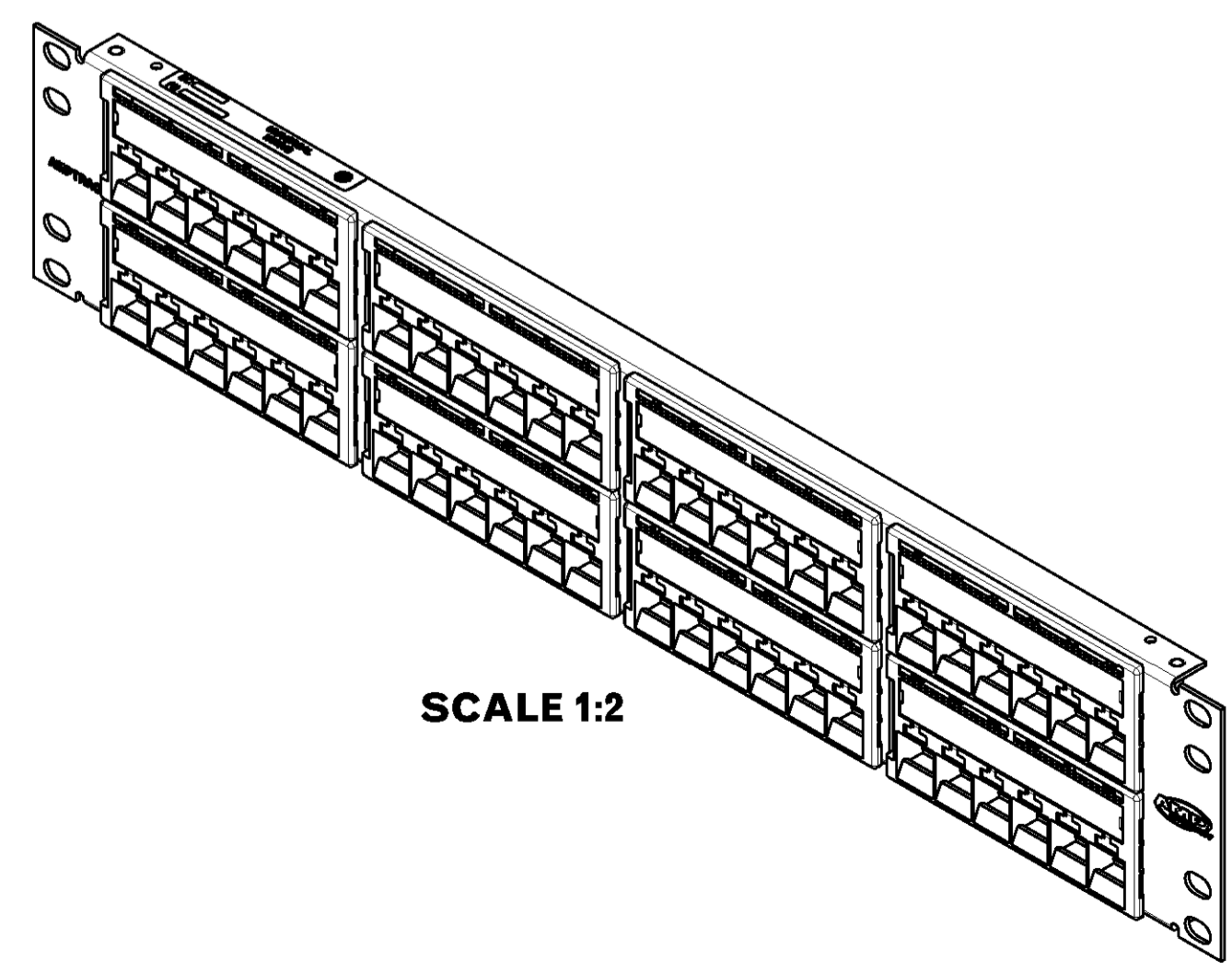
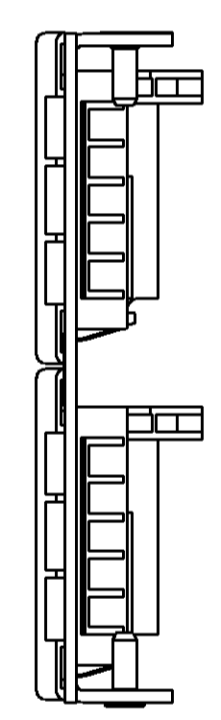
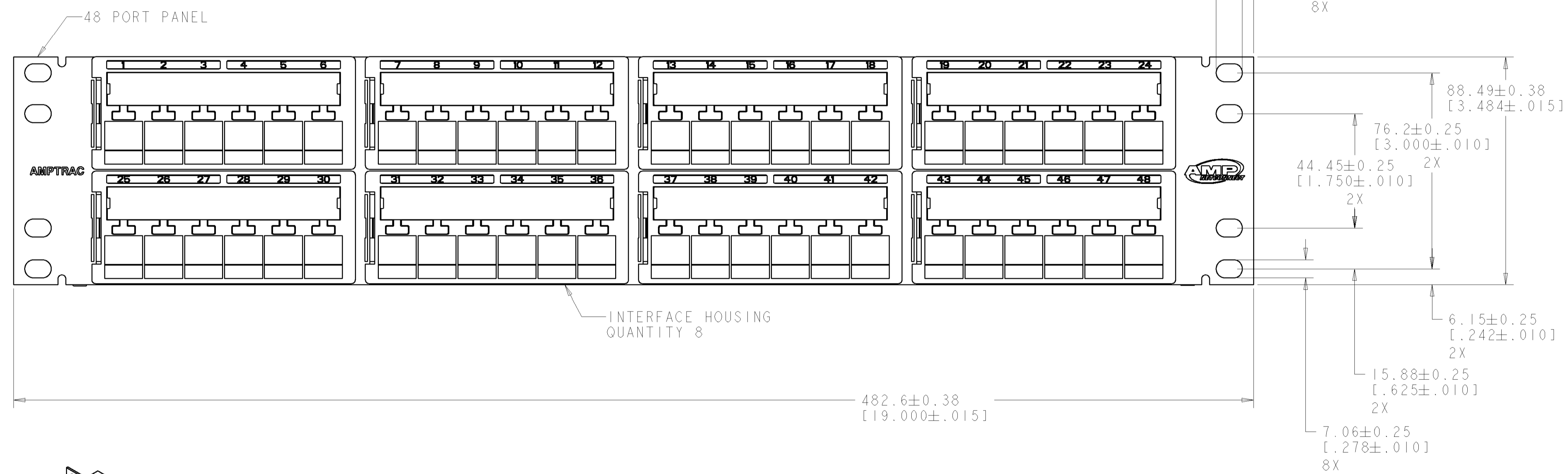
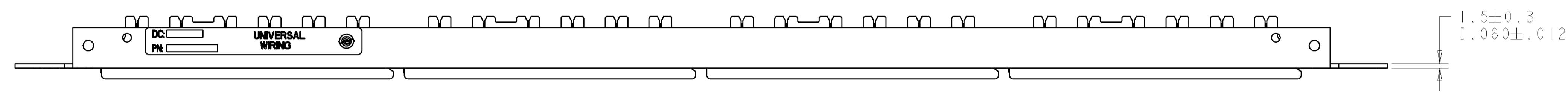

1933324-1
 PART NUMBER

DIMENSIONS: MMI [INCHES]		TOLERANCES UNLESS OTHERWISE SPECIFIED: 0 PLC ± 1 PLC ± 2 PLC ± 3 PLC ± 4 PLC ± ANGLES ±		DWN J MCNEAL 24MAY2007 CHK S HERNDON 24MAY2007 APVD S HERNDON 24MAY2007	tyco Electronics Tyco Electronics Harrisburg, PA 17105-3608
MATERIAL: △		FINISH: △		NAME KIT, PATCH PANEL ASSEMBLY, AMPTRAC 2U, 48 PORT, MULTIMEDIA, FLAT PRODUCT SPEC APPLICATION SPEC	SIZE CAGE CODE DRAWING NO RESTRICTED TO A 00779 C-1933324 -
CUSTOMER DRAWING				WEIGHT -	SCALE 1:1 SHEET 1 OF 1 REV B